

FY 512 M

Material Cast iron

Dimensions

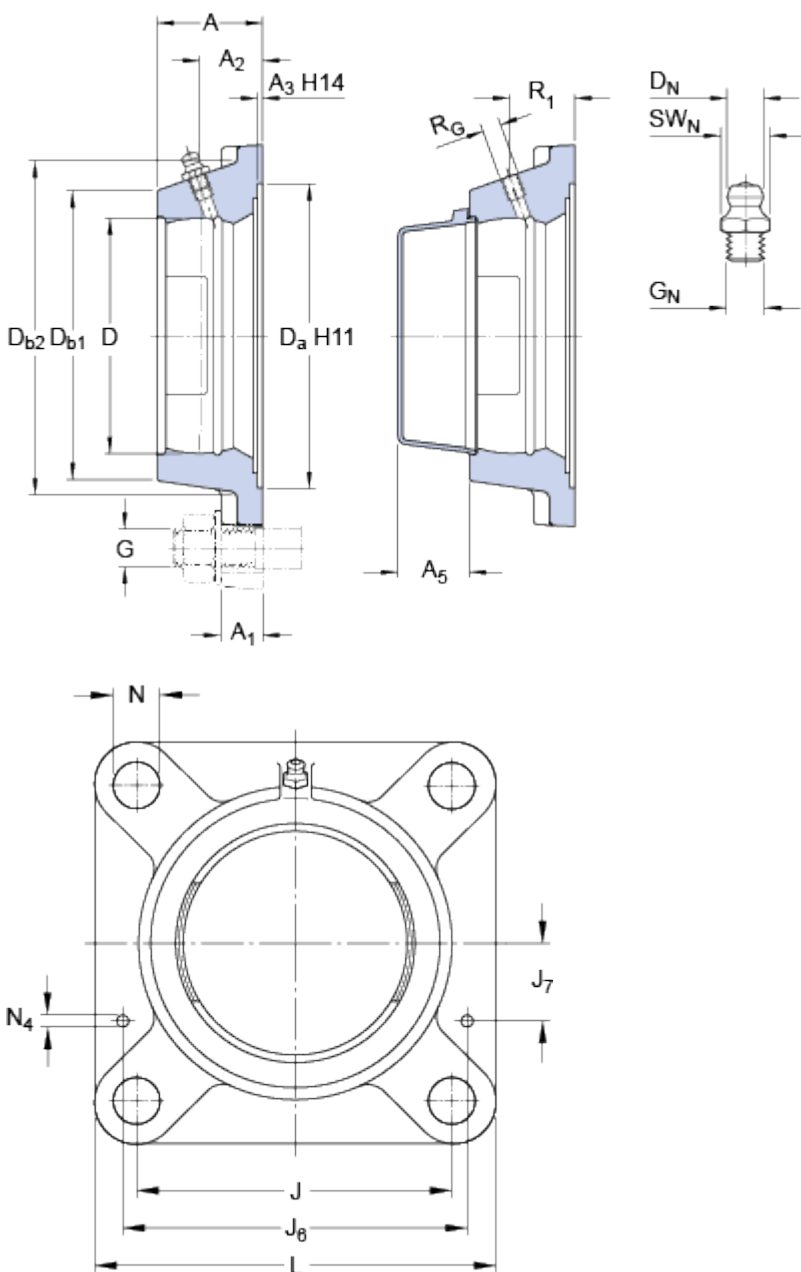

D	110	mm
D _a	161.9	mm
D _{b1}	130	mm
D _{b2}	143	mm
A	52	mm
A ₁	17	mm
A ₂	34	mm
A ₃	3.2	mm
A ₅	35.5	mm
J	143	mm
L	175	mm
N	18	mm

Threaded hole

R _G	1/4-28 UNF	
R ₁	34.5	mm

Grease fitting

D _N	6.5	mm
SW _N	7	mm
G _N	1/4-28 SAE-LT	

Dowel pins

J ₆	161	mm
J ₇	49.5	mm
N ₄	4	mm

Mass

Mass housing 2.5 kg

Mounting information

Recommended diameter for attachment bolts, mm	G	16	mm
Recommended diameter for attachment bolts, inch	G	0.625	in

Associated products

End cover	ECY 212
-----------	---------
