

# SY 505 M

Material

Cast iron

## Dimensions

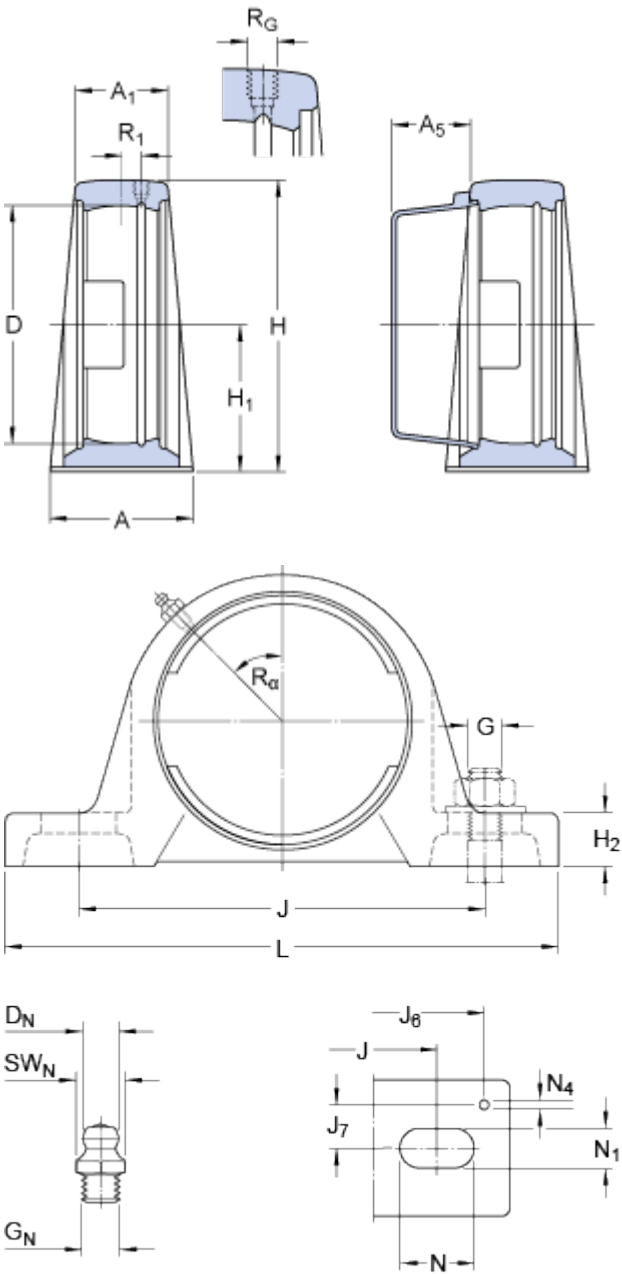

D	52	mm
H <sub>1</sub>	36.5	mm
A	36	mm
A <sub>1</sub>	22	mm
A <sub>5</sub>	18	mm
H	70	mm
H <sub>2</sub>	16	mm
J	102	mm
J	max. 110	mm
J	min. 94	mm
L	130	mm
N	19.5	mm
N <sub>1</sub>	11.5	mm

### Threaded hole

R <sub>G</sub>	1/4-28 UNF	
R <sub>1</sub>	2	mm
R <sub>α</sub>	45	°

### Grease fitting

D <sub>N</sub>	6.5	mm
SW <sub>N</sub>	7	mm
G <sub>N</sub>	1/4-28 SAE-LT	

### Dowel pins

J <sub>6</sub>	120	mm
J <sub>7</sub>	13	mm
N <sub>4</sub>	4	mm

Mass housing

0.53

kg

---

### Mounting information

Recommended diameter for attachment bolts, mm

G

10

mm

Recommended diameter for attachment bolts, inch

G

0.375

in

---

### Associated products

End cover

ECY 205

---