

SY 504 M

Material

Cast iron

Dimensions

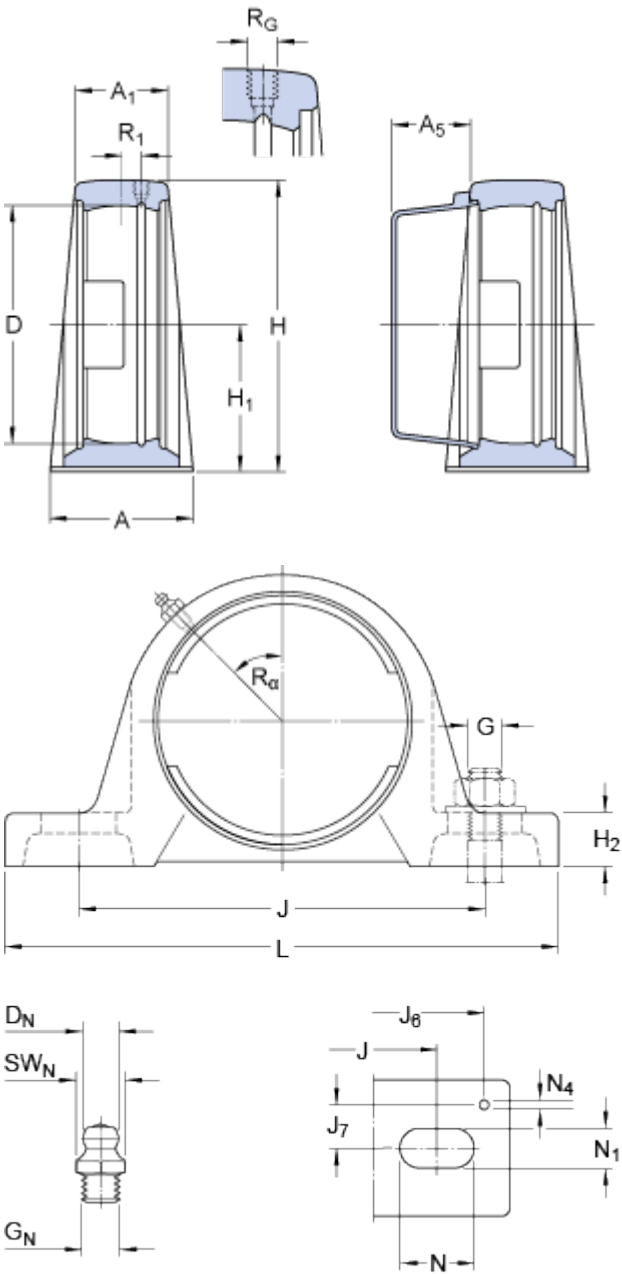

D	47	mm
H ₁	33.3	mm
A	32	mm
A ₁	21	mm
A ₅	18.5	mm
H	64.5	mm
H ₂	14	mm
J	97	mm
J	max. 106	mm
J	min. 88	mm
L	127	mm
N	20.5	mm
N ₁	11.5	mm

Threaded hole

R _G	1/4-28 UNF	
R ₁	2	mm
R _α	45	°

Grease fitting

D _N	6.5	mm
SW _N	7	mm
G _N	1/4-28 SAE-LT	

Dowel pins

J ₆	118	mm
J ₇	11.5	mm
N ₄	2	mm

Mass housing

0.41

kg

Mounting information

Recommended diameter for attachment bolts, mm

G

10

mm

Recommended diameter for attachment bolts, inch

G

0.375

in

Associated products

End cover

ECY 204
