

SY 506 M

Material Cast iron

Dimensions

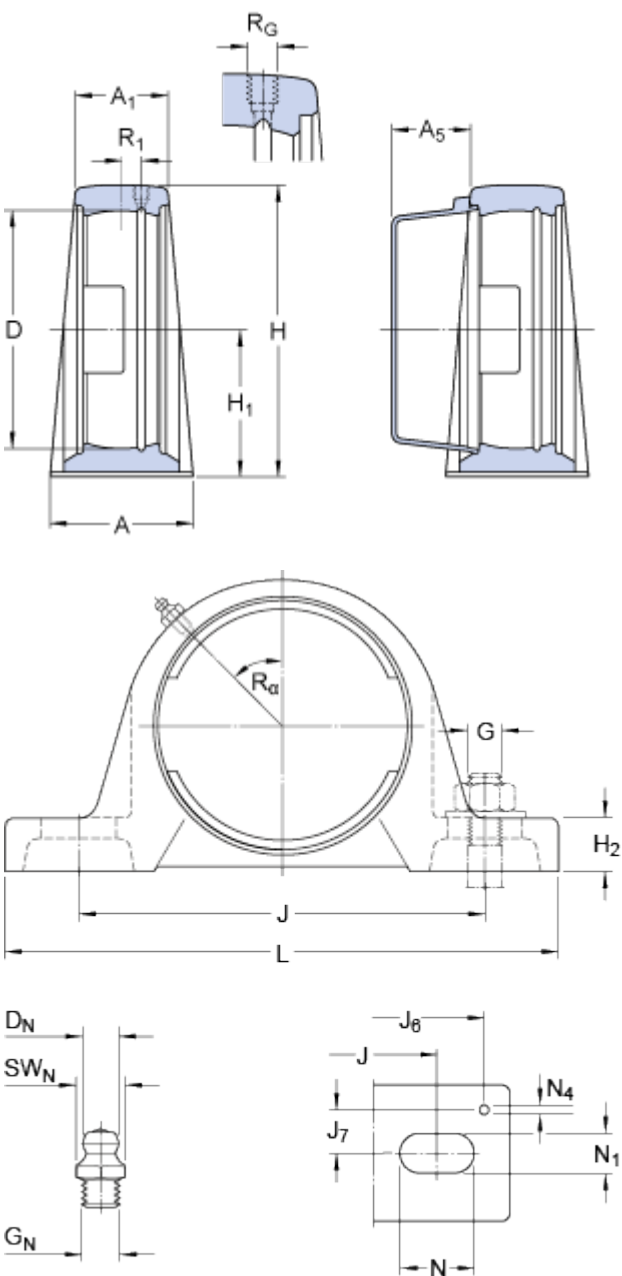

D	62	mm
H ₁	42.9	mm
A	40	mm
A ₁	25	mm
A ₅	20	mm
H	82	mm
H ₂	17	mm
J	117.5	mm
J	max. 127	mm
J	min. 108	mm
L	152	mm
N	23.5	mm
N ₁	14	mm

Threaded hole

R _G	1/4-28 UNF	
R ₁	3	mm
R _α	45	°

Grease fitting

D _N	6.5	mm
SW _N	7	mm
G _N	1/4-28 SAE-LT	

Dowel pins

J ₆	140	mm
J ₇	14	mm
N ₄	4	mm

Mass housing

0.76

kg

Mounting information

Recommended diameter for attachment bolts, mm

G

12

mm

Recommended diameter for attachment bolts, inch

G

0.5

in

Associated products

End cover

ECY 206
